

Insulation monitoring relay CM-IWN.1

For unearthed AC, DC and mixed AC/DC systems up to $U_n = 400 \text{ V AC}$ and 600 V DC

The CM-IWN.1 serves to monitor insulation resistance in accordance with IEC 61557-8 in unearthed IT AC systems, IT AC systems with galvanically connected DC circuits, or unearthed IT DC systems with a voltage up to 400 V AC and 600 V DC. The measuring range can be extended up to 690 V AC and 1000 V DC by using the coupling unit CM-IVN. It can be configured to the requirements of the applications and therefore used multi-functional.

The CM-IWN.1 is available with two different terminal versions. You can choose between the proven screw connection technology (double-chamber cage connection terminals) and the completely tool-free Easy Connect Technology (push-in terminals).

Characteristics

- For monitoring the insulation resistance of unearthed IT systems up to $U_n = 400 \text{ V AC}$ and 600 V DC
- According to IEC/EN 61557-8 "Electrical safety in low voltage distribution systems up to 1000 V a.c. and 1500 V d.c. – Equipment for testing, measuring or monitoring of protective measures – Part 8: Insulation monitoring devices for IT systems"
- Rated control supply voltage 24-240 V AC/DC
- Prognostic measuring principle with superimposed square wave signal
- Two measuring ranges 1-100 k Ω and 2-200 k Ω
- One (1 x 2 c/o) or two (2 x 1 c/o) threshold values $R_{an1}/R1^{1)}$ (final switch-off) and $R_{an2}/R2^{1)}$ (prewarning) configurable²⁾
- Precise adjustment of the threshold values in 1 k Ω steps (R1) and 2 k Ω steps (R2)
- Interrupted wire detection configurable
- Non-volatile fault storage configurable
- Open- or closed-circuit principle configurable
- Precise adjustment by front-face operating controls
- Screw connection technology or Easy Connect Technology available



- Housing material for highest fire protection classification UL 94 V-0
- Tool-free mounting on DIN rail as well as demounting
- 45 mm (1.77 in) width
- 3 LEDs for the indication of operational states

¹⁾ term acc. to IEC/EN 61557-8

²⁾ R2 only active with 2 x 1 c/o configuration

Approvals

- UL 508, CAN/CSA C22.2 No.14
- GL
- IEC/EN 60947-5-1, CB scheme
- GB14048.5 - 2001, CCC
- GOST
- RMRS

Marks

- CE
- C-Tick

Order data

Insulation monitoring relay

Type	Nominal voltage U_n of the distribution system to be monitored	Rated control supply voltage	System leakage capacitance, max.	Connection technology	Order code
CM-IWN.1P	0-400 V AC / 0-600 V DC	24-240 V AC/DC	20 μ F	Push-in terminals	1SVR 760 660 R0200
CM-IWN.1S				Screw type terminals	1SVR 750 660 R0200

Accessories

Type	Description	Order code
CM-IVN.P	Coupling unit for connection of the CM-IWN to systems with voltages U_n up to 690 V AC and 1000 V DC with Push-in terminals	1SVR 760 669 R9400
CM-IVN.S	Coupling unit for connection of the CM-IWN to systems with voltages U_n up to 690 V AC and 1000 V DC with Screw type terminals	1SVR 750 669 R9400
ADP.02	Adapter for screw mounting	1SVR 440 029 R0100
MAR.12	Marker label for devices with DIP switches	1SVR 730 006 R0000
COV.12	Sealable transparent cover	1SVR 750 005 R0100

Connection technology

Maintenance free Easy Connect Technology with push-in terminals

Type designation CM-xxN.yyP

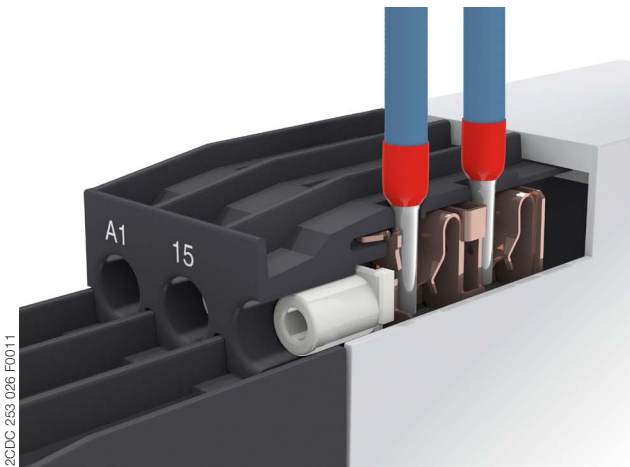

Push-in terminals

- Tool-free connection of rigid and flexible wires with wire end ferrule according to DIN 46228-1-A, DIN 46228-4-E
Wire size: 2 x 0.5-1.5 mm², (2 x 20 - 16 AWG)
- Easy connection of flexible wires without wire end ferrule by opening the terminals
- No retightening necessary
- One operation lever for opening both connection terminals
- For triggering the lever and disconnecting of wires you can use the same tool (Screwdriver according to DIN ISO 2380-1 Form A 0.8 x 4 mm (0.0315 x 0.157 in), DIN ISO 8764-1 PZ1 ø 4.5 mm (0.177 in))
- Constant spring force on terminal point independent of the applied wire type, wire size or ambient conditions (e. g. vibrations or temperature changes)
- Opening for testing the electrical contacting
- Gas-tight

Approved screw connection technology with double-chamber cage connection terminals

Type designation CM-xxN.yyS

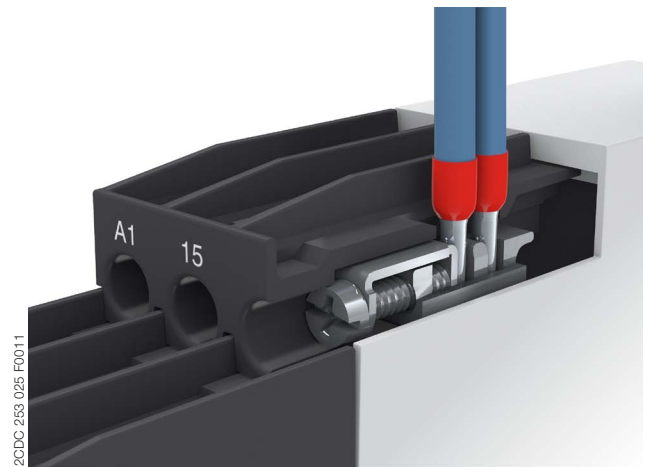

Double-chamber cage connection terminals

- Terminal spaces for different wire sizes:
fine-strand with/without wire end ferrule:
1 x 0.5-2.5 mm² (2 x 20 - 14 AWG),
2 x 0.5-1.5 mm² (2 x 20 - 16 AWG)
rigid:
1 x 0.5-4 mm² (1 x 20 - 12 AWG),
2 x 0.5-2.5 mm² (2 x 20 - 14 AWG)
- One screw for opening and closing of both cages
- Pozidrive screws for pan- or crosshead screwdrivers according to DIN ISO 2380-1 Form A 0.8 x 4 mm (0.0315 x 0.157 in), DIN ISO 8764-1 PZ1 ø 4.5 mm (0.177 in)

Both the Easy Connect Technology with push-in terminals and screw connection technology with double-chamber cage connection terminals have the same connection geometry as well as terminal position.

Functions

Operating controls

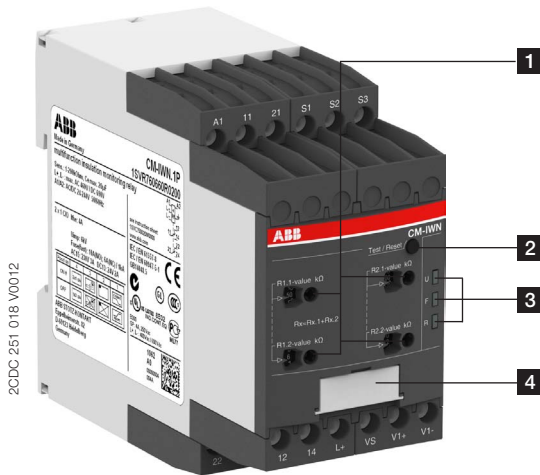

1 Front-face rotary switches to adjust the threshold value:

R1.1 for R1 tens figure:

0, 10, 20, 30, 40, 50, 60, 70, 80, 90 k Ω in ten k Ω steps

R1.2 for R1 units figure:

1, 2, 3, 4, 5, 6, 7, 8, 9, 10 k Ω in one k Ω steps

R2.1 for R2 tens figure:

0, 20, 40, 60, 80, 100, 120, 140, 160, 180 k Ω in twenty k Ω steps

R2.2 for R2 units figure:

2, 4, 6, 8, 10, 12, 14, 16, 18, 20 k Ω in two k Ω steps

2 Test and reset button

3 Indication of operational states

U: green LED – control supply voltage

F1: red LED – fault message

F2: yellow LED – relay status

4 DIP switches (see DIP switch functions)

Application / monitoring function

The CM-IWN.1 serves to monitor insulation resistance in accordance with IEC 61557-8 in unearthed IT AC systems, IT AC systems with galvanically connected DC circuits, or unearthed IT DC systems.

The insulation resistance between system lines and system earth is measured. If this falls below the adjustable threshold values, the output relays switch into the fault state.

The device can monitor control circuits (single-phase) and main circuits (3-phase).

Supply systems with voltages $U_n = 0-400$ V AC (15-400 Hz) or 0-600 V DC can be directly connected to the measuring inputs and their insulation resistance being monitored. For systems with voltages above 400 V AC and 600 V DC the coupling unit CM-IVN can be used for the expansion of the CM-IWN.1 voltage range.

Measuring principle

A pulsating measuring signal is fed into the system to be monitored and the insulation resistance calculated.

This pulsating measuring signal alters its form depending on the insulation resistance and system leakage capacitance. From this altered form the change in the insulation resistance is forecast.

When the forecast insulation resistance corresponds to the insulation resistance calculated in the next measurement cycle and is smaller than the set threshold value, the output relays are activated or deactivated, depending on the device configuration. This measuring principle is also suitable for the detection of symmetrical insulation faults.

Additional monitoring functions



When interrupted wire detection  is activated, the CM-IWN.1 automatically controls the system/measuring circuit connections L+ and L- when the system starts up. This can be repeated at any time by activating the test function.

The CM-IWN.1 cyclically monitors the measuring circuit connections \perp and KE for wire interruption. In case of a wire interruption in one of the connections, the output relays switch to the fault state.

In addition, the unearthed AC-, DC- or AC/DC system is monitored for inadmissible system leakage capacitance. If the system leakage capacitance is too high, the output relays switch to the fault state.

Also incorrect settings that could cause a faulty function of the device are monitored. When the device detects such an incorrect setting, the output relays switch to the fault state.

Operating mode

The system to be monitored is connected to terminals L+ and L-. The earth potential is connected to terminals \perp and KE. Depending on the setting, the device operates according to the open-circuit principle  (fault state: relay energized) or closed-circuit principle  (fault state: relay de-energized).

Once the control supply voltage has been applied the insulation monitoring relay runs through a system test routine. The system is diagnosed and the settings are tested. If no internal or external faults are found after this test routine is completed, the output relays switch into the operational state.

All operating states are signalled by the front-face LEDs. See table "LEDs, status information and fault messages" on page 10.

Configuration 1 x 2 c/o contacts (final switch-off)

With this configuration the settings for the threshold value for prewarning (R2) have no influence on the operating function. If the measured value drops below the set threshold value, the output relays switch into the fault state. If the measured value exceeds the threshold value plus hysteresis, the output relays switch back into their original state.

Configuration 2 x 1 c/o contact (prewarning and final switch-off)

If the measured value drops below the set threshold value for prewarning the second output relay 21-22/24 switches. If the measured value drops below the threshold value for final switch-off, the first output relay 11-12/14 switches.

If the measured value exceeds the threshold value for final switch-off plus hysteresis, the first output relay 11-12/14 switches back into its original state. If the measured value exceeds the threshold value for prewarning plus hysteresis, also the second output relay 21-22/24 switches back to its original state.

Test function

The test function is only possible when there is no fault.

By pressing the front-face combined test/reset button a system test routine is executed. The output relays switch to the fault state as long as the test/reset button is pressed, the control contact S1-S3 is closed (or the test functions are processed).

The test function can be activated either with the front-face combined test/reset button or with a remote test button connected as shown in the picture.

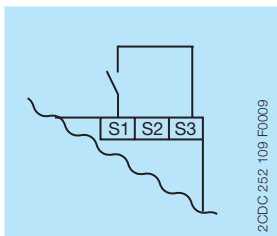



Fault storage, reset function and remote reset

When fault storage  is active, the output relays remain in the fault state and only switch back to their original state after the combined test/reset button is pressed or after the remote reset (terminals S2-S3) is activated, and when the insulation resistance is higher than the set threshold value(s) plus hysteresis.

The fault storage is designed non-volatile (remanent). This means that after switch-off and return of the control supply voltage the device returns to the state it was prior to the switch-off until a reset is executed.

Depending on the configuration of DIP switch 2, there are several possibilities of resetting the device, as shown in the picture.

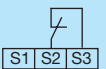
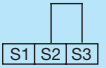
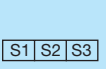
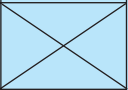
DIP switch 2		
	1.) Front 2.) Remote 3.) A1-A2	1.) Front 2.) Remote
	1.) Front 2.) A1-A2	1.) Front
	1.) Auto-Reset	

2CDC 252 110 F0009

Measuring range expansion by using the coupling unit CM-IVN

The coupling unit CM-IVN serves to connect the CM-IWN.1 to systems up to 690 V AC and 1000 V DC. Terminals VS, V1+, V1- are connections for the coupling unit.

Function descriptions/diagrams

□ Control supply voltage not applied / Output contact open / LED OFF

■ Control supply voltage applied / Output contact closed / LED ON

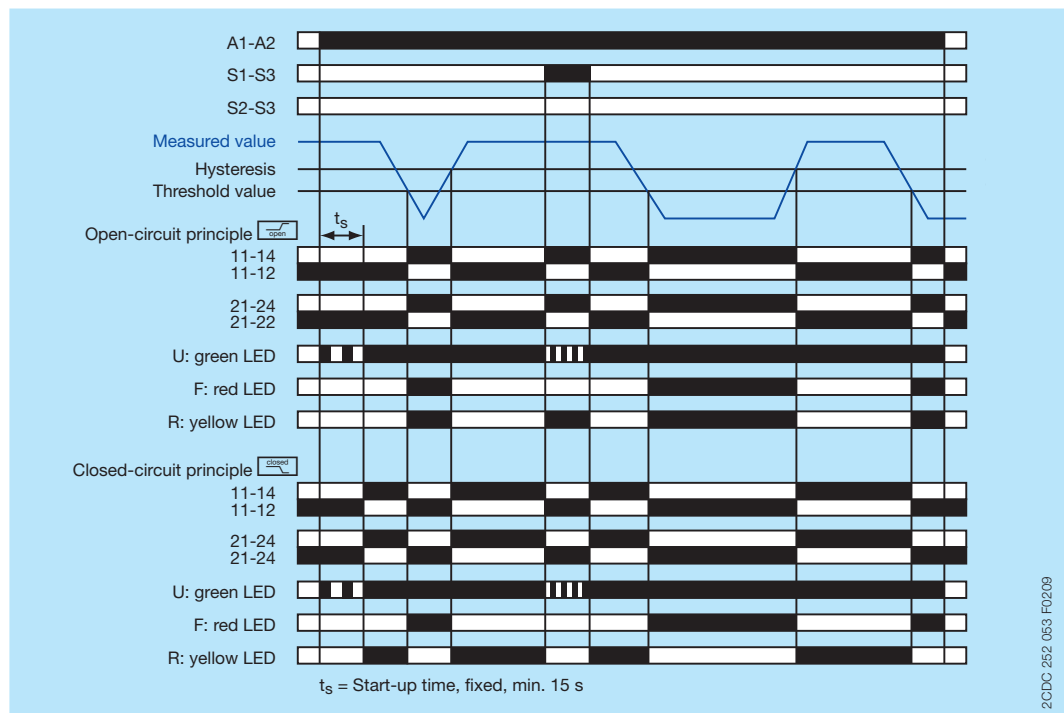

Insulation resistance monitoring w/o fault storage , auto reset, 1 x 2 c/o

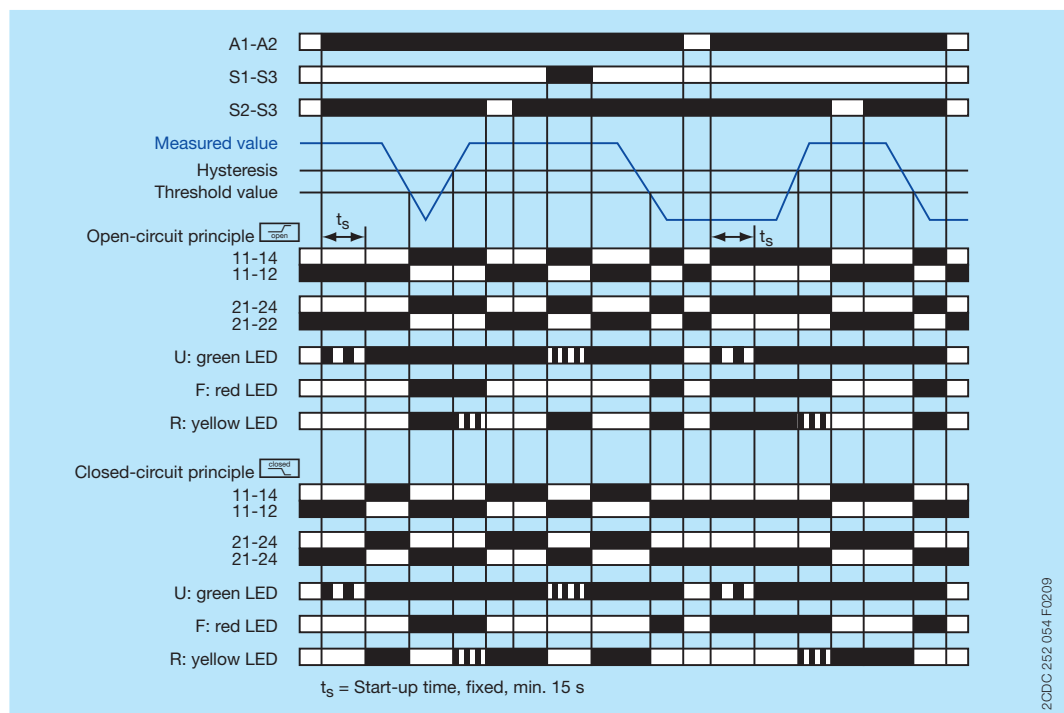

Insulation resistance monitoring with fault storage , manual reset, 1 x 2 c/o

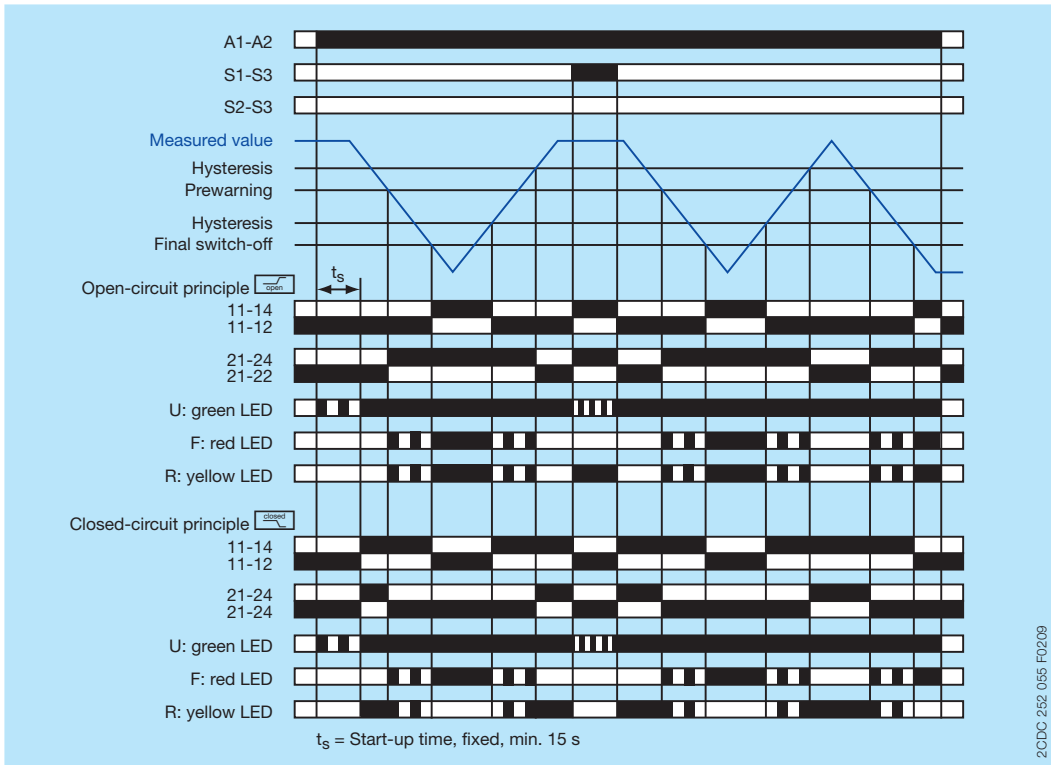

Insulation resistance monitoring w/o fault storage , auto reset, 2 x 1 c/o

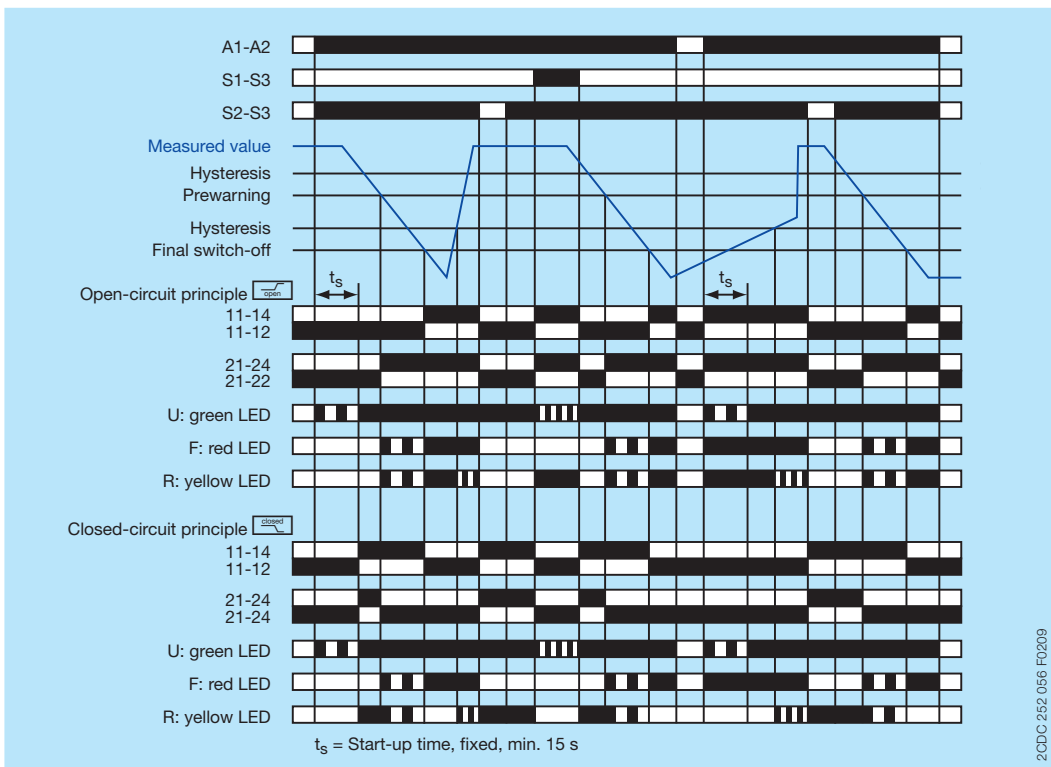

Insulation resistance monitoring with fault storage , manual reset, 2 x 1 c/o

Connection and wiring

Connection diagram

A1	11	21	S1	S2	S3
----	----	----	----	----	----

12	14	L+	VS	V1+	V1-
22	24	L-	KE	⊥	A2

A1-A2	Control supply voltage
S1-S3	Remote test
S2-S3	Remote reset
L+, L-	Measuring circuit/input, system connection
⊥, KE	Measuring circuit/input, earth connections
VS, V1+, V1-	Connections for the coupling unit (if used)
11-12/14	Output relay 1, open- or closed-circuit principle
21-22/24	Output relay 2, open- or closed-circuit principle

Wiring diagrams

Always connect L+ and L- to different conductors. L+ and L- can be connected to any of the conductors.
 $U_n \leq 400 \text{ V AC}$; 600 V DC (For monitoring of systems with higher voltages, use coupling unit CM-IVN.)

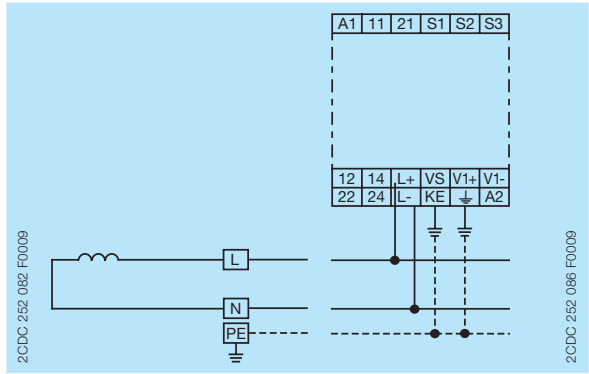

2-wire AC system

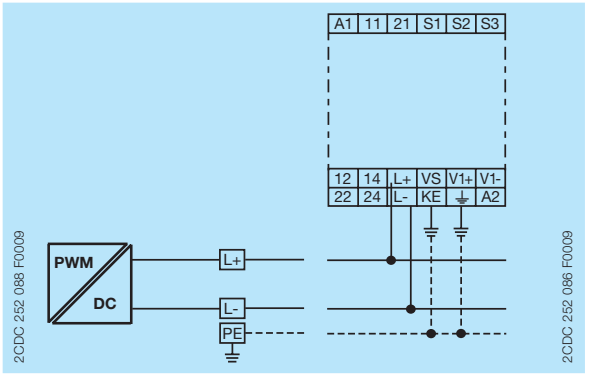

2-wire DC system

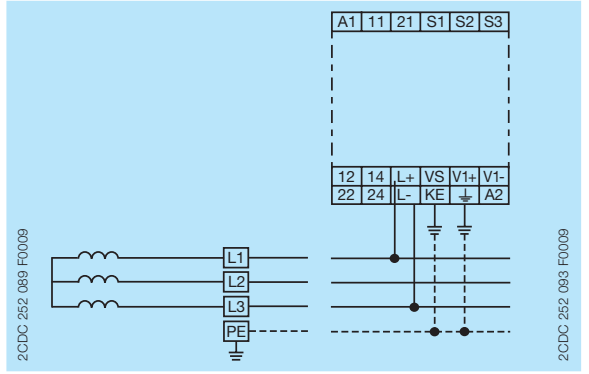

3-wire AC system

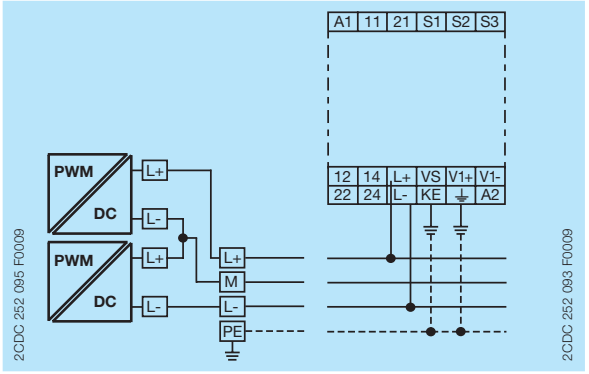

3-wire DC system

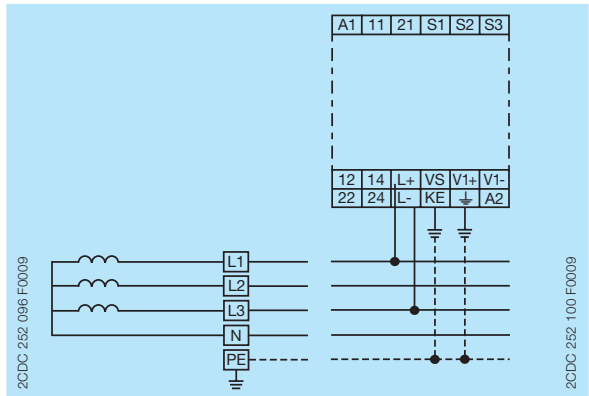

4-wire AC system





Configuration and settings

Rotary switches R1.1, R1.2, R2.1 and R2.2 (threshold values)









By means of four separate 10 position rotary switches  with direct reading scales, the threshold values for the insulation resistance R_F of the systems to be monitored can be adjusted.

With the Rx.1 rotary switch the tens figure is set and with the Rx.2 rotary switch the units figure is set. The set threshold value is then the addition of the two values. For example, R1.1 set to 70 and R1.2 set to 8 leads to a threshold value for R1 of 78 k Ω .

DIP switches











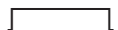
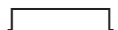



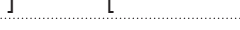

Position	4	3	2	1
ON \uparrow	2x1 c/o			closed
OFF	1x2 c/o			open

2CDC 252 050 F0b09

	ON	OFF (default)
DIP switch 1 Operating principle of the output relays	Closed-circuit principle  If closed-circuit principle is selected, the output relays are energized. They de-energize if a fault is occurring.	Open-circuit principle  If open-circuit principle is selected, the output relays are de-energized. They energize if a fault is occurring.
DIP switch 2 Non-volatile fault storage	Fault storage activated (latching)  If the fault storage function is activated, the output relays remain in tripped position until a reset is done either by the front-face button or by the remote reset connection S2-S3. This function is non-volatile.	Fault storage de-activated (non latching)  If the fault storage function is de-activated, the output relays switch back to their original position as soon as the insulation fault no longer exists.
DIP switch 3 Interrupted wire detection	Interrupted wire detection activated  With this configuration, the CM-IWN.1 monitors the wires connected to L+ and L- for interruptions.	Interrupted wire detection de-activated  With this configuration the interrupted wire detection is de-activated.
DIP switch 4 2 x 1 c/o, 1 x 2 c/o	2 x 1 c/o (SPDT) contact  If operating principle 2 x 1 c/o contact is selected, the output relay R1 (11-12/14) reacts to threshold value R1 (final switch-off) and the output relay R2 (21-22/24) reacts to threshold value R2 (prewarning)	1 x 2 c/o (SPDT) contacts  If operating principle 1 x 2 c/o contacts is selected, both output relays R1 (11-12/14) and R2 (21-22/24) react synchronously to threshold value R1 (final switch-off). Settings of the threshold value R2 have no effect on the operation.

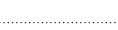
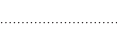
Operating state indication

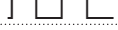
LEDs, status information and fault messages

Operational state	LED U (green)	LED F (red)	LED R (yellow)
Start-up		OFF	OFF
No fault		OFF	¹⁾
Prewarning			
Insulation fault (below threshold value)			¹⁾
KE/⊥ wire interruption			¹⁾
L+/L- wire interruption during system start-up / test function			¹⁾
System leakage capacitance too high / invalid measurement result			¹⁾
Internal system fault	¹⁾		¹⁾
Setting fault ²⁾			
Test function		OFF	¹⁾
No fault after fault storage ³⁾		⁴⁾	

¹⁾ Depending on the configuration (see "Function descriptions/diagrams" on page 6).

²⁾ Possible faulty setting: The threshold value for final switch-off is set at a higher value than the threshold value for prewarning.

³⁾ The device has triggered after an insulation fault. The fault has been stored and the insulation resistance has returned to a higher value than the threshold value plus hysteresis.

⁴⁾ Depending on the fault

Application examples

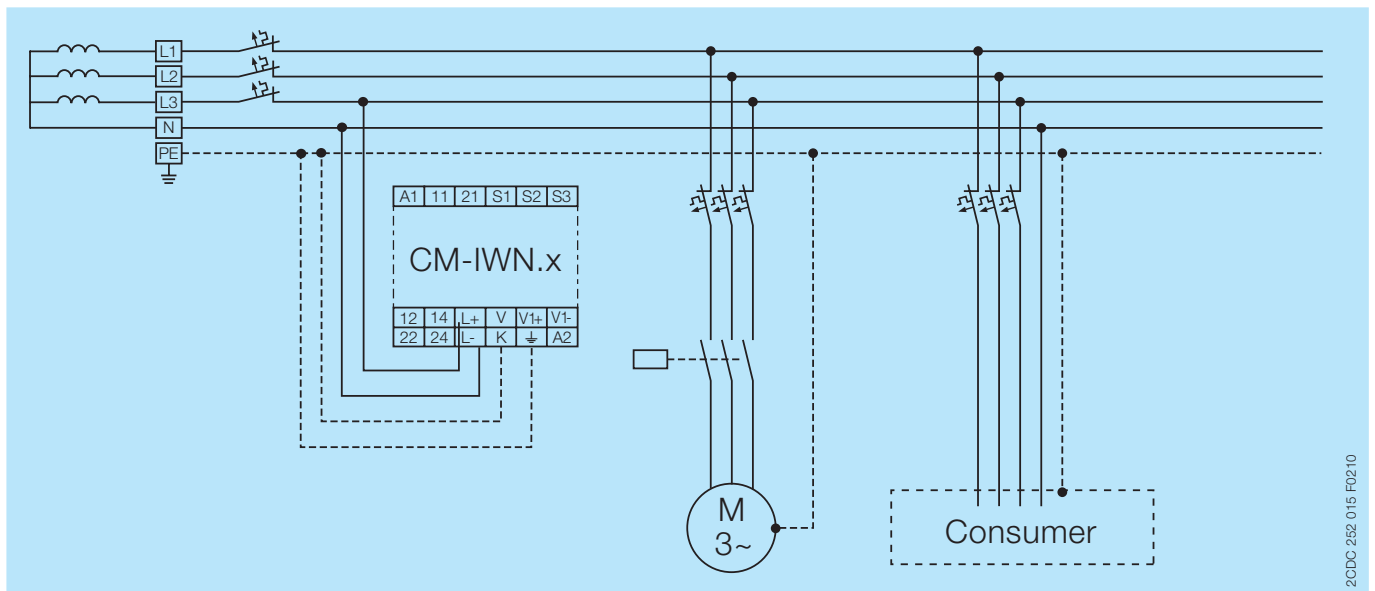

2CDC 252 015 F0210

Earth fault / insulation resistance monitoring of an unearthed 4-wire AC system

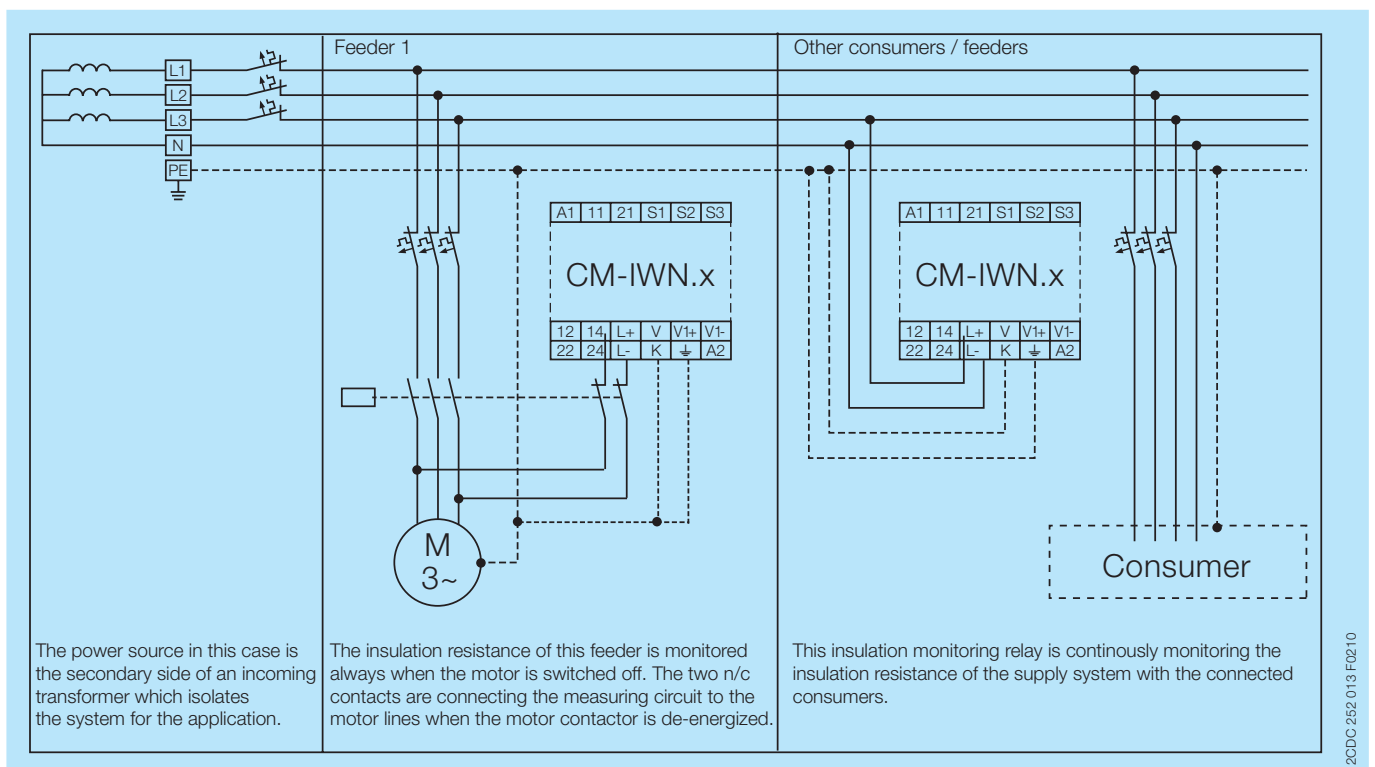

2CDC 252 013 F0210

Earth fault / insulation resistance monitoring of different feeder circuits with fault localization

Technical data

Data at $T_a = 25\text{ °C}$ and rated values, unless otherwise indicated

Input circuits

Input circuit - Supply circuit	A1 - A2
Rated control supply voltage U_s	24-240 V AC/DC
Rated control supply voltage tolerance	-15...+10 %
Typical current / power consumption	24 V DC 55 mA / 1.3 VA 115 V AC 20 mA / 2.3 VA 230 V AC 15 mA / 3.5 VA
Rated frequency f_s	DC or 15-400 Hz
Frequency range AC	13.5-440 Hz
Power failure buffering time	min. 20 ms
Start-up time t_s	15 ms

Input circuit - Measuring circuit	L+, L-, \perp , KE
Monitoring function	insulation resistance monitoring of IT systems (IEC/EN 61557-8)
Measuring principle	prognostic measuring principle with superimposed square wave signal
Nominal voltage U_n of the distribution system to be monitored	0-400 V AC / 0-600 V DC
Voltage range of the distribution system to be monitored	0-460 V AC / 0-690 V DC (tolerance +15 %)
Rated frequency f_N of the distribution system to be monitored	DC or 15-400 Hz
Tolerance of the rated frequency f_N	13.5-440 Hz
System leakage capacitance C_e	max. 20 μ F
Extraneous DC voltage U_{fg} (when connected to an AC system)	max. 460 V DC
Voltage range expansion of the measuring input with coupling unit CM-IVN	use connection terminals V1+, V1-, VS max. length of connection cable 40 cm
Number of possible response / threshold values	2
Adjustment range of the specified response value R_{an} (threshold)	min.-max. R1 1-100 k Ω min.-max. R2 2-200 k Ω (activated/de-activated by DIP switch)
Adjustment resolution	R1 1 k Ω R2 2 k Ω
Tolerance of the adjusted threshold value / Relative percentage uncertainty A at -5...+45 °C, $U_n = 0-115\%$, $U_s = 85-110\%$, f_N, f_s , $C_e = 1\mu$ F	at 1-15 k Ω R_F ± 1 k Ω / in combination with CM-IVN ± 1.5 k Ω at 15-200 k Ω R_F $\pm 8\%$
Hysteresis related to the threshold value	25 %; min. 2 k Ω
Internal impedance Z_i	at 50 Hz 155 k Ω
Internal DC resistance R_i	185 k Ω
Measuring voltage U_m	24 V
Tolerance of measuring voltage U_m	+10 %
Measuring current I_m	0.15 mA
Response time t_{an}	
pure AC system	0.5 x R_{an} and $C_e = 1\mu$ F max. 10 s
DC system or AC system with connected rectifiers	max. 15 s
Repeat accuracy (constant parameters)	< 0.1 % of full scale
Accuracy of R_a (measured value) within the rated control supply voltage tolerance	< 0.05 % of full scale
Accuracy of R_a (measured value) within the operation temperature range	at 1-10 k Ω R_F 5 Ω / K at 10-200 k Ω R_F 0.05 % / K
Transient overvoltage protection (\perp - terminal)	avalanche diode

Input circuit - Control circuits		S1 - S2 - S3
Control inputs - volt free	S1-S3	remote test
	S2-S3	remote reset
Maximum switching current in the control circuit		1 mA
Maximum cable length to the control inputs		50 m - 100 pF/m (164 ft - 30.5 pF/ft)
Minimum control pulse length		150 ms
No-load voltage at the control input		≤ 24 V DC

User interface

Indication of operational states		
Control supply voltage	U	green LED
Fault message	F	red LED
Relay status	R	yellow LED

Details see table "LEDs, status information and fault messages" on page 10 and "Function descriptions/diagrams" on page 6

Operating elements and controls		
Adjustment of threshold value R1	R1.1	rotary switch, 10 kΩ steps for the tens figure
	R1.2	rotary switch, 1 kΩ steps for the units figure
Adjustment of threshold value R2	R2.1	rotary switch, 20 kΩ steps for the tens figure
	R2.2	rotary switch, 2 kΩ steps for the units figure
Configuration of	DIP switch 1	operating principle of the output relays
	DIP switch 2	non volatile fault storage
	DIP switch 3	interrupted wire detection
	DIP switch 4	2 x 1 c/o, 1 x 2 c/o

Output circuits

Kind of output	11-12/14	relay, 1st c/o (SPDT) contact
	21-22/24	relay, 2nd c/o (SPDT) contact
Operating principle		2 x 1 or 1 x 2 c/o (SPDT) contacts configurable
Contact material		open- or closed-circuit principle ¹⁾ configurable
Rated operational voltage (IEC/EN 60947-1)		AgNi alloy, Cd free
Minimum switching voltage / Minimum switching current		250 V AC / 300 V DC
Maximum switching voltage / Maximum switching current		24 V / 10 mA
Rated operational current I _e (IEC/EN 60947-5-1)	AC12 (resistive) at 230 V	see "Load limits curves" on page 16
	AC15 (inductive) at 230 V	4 A
	DC12 (resistive) at 24 V	3 A
	DC13 (inductive) at 24 V	4 A
AC rating (UL 508)	Utilization category	B 300, pilot duty general purpose (250 V, 4 A, cos φ 0.75)
	(Control Circuit Rating Code)	
	max. rated operational voltage	250 V AC
	max. continuous thermal current at B 300	4 A
	max. making/breaking apparent power at B 300	3600/360 VA
Mechanical lifetime		30 x 10 ⁶ switching cycles
Electrical lifetime	AC12, 230 V, 4 A	0.1 x 10 ⁶ switching cycles
Max. fuse rating to achieve short-circuit protection	n/c contact	6 A fast-acting
	n/o contact	10 A fast-acting
Conventional thermal current I _{th} (IEC/EN 60947-1)		4 A

1) Closed-circuit principle: Output relay(s) de-energize(s) if measured value falls below the adjusted threshold value R_{an}

Open-circuit principle: Output relay(s) energize(s) if measured value falls below the adjusted threshold value R_{an}

General data

MTBF		on request
Duty time		100 %
Dimensions (W x H x D)		45 x 78 x 100 mm (1.78 x 3.07 x 3.94 in)
		Screw connection technology
		Easy Connect Technology (push-in)
Weight	gross weight	0,241 kg (0.531 lb)
	net weight	0.270 kg (0.595 lb)
Mounting		DIN rail (IEC/EN 60715), snap-on mounting without any tool
Mounting position		any
Minimum distance to other units	vertical / horizontal	not necessary / 10 mm (0.39 in) at $U_n > 400$ V
Degree of protection	housing / terminal	IP50 / IP20

Electrical connection

		Screw connection technology	Easy Connect Technology (push-in)
Wire size	fine-strand with(out) wire end ferrule	1 x 0.5-2.5 mm ² (1 x 20-14 AWG)	2 x 0.5-1.5 mm ² (2 x 20-16 AWG)
		2 x 0.5-1.5 mm ² (2 x 20-16 AWG)	
	rigid	1 x 0.5-4 mm ² (1 x 20-12 AWG)	2 x 0.5-1.5 mm ² (2 x 20-16 AWG)
		2 x 0.5-2.5 mm ² (2 x 20-14 AWG)	
Stripping length		8 mm (0.32 in)	
Tightening torque		0.6 - 0.8 Nm (5.31 - 7.08 lb.in)	-

Environmental data

Ambient temperature ranges	operation	-25...+60 °C
	storage	-40...+85 °C
	transport	-40...+85 °C
Climatic category	IEC/EN 60721-3-3	3K5 (no condensation, no ice formation)
Damp heat, cyclic	IEC/EN 60068-2-30	6 x 24 h cycle, 55 °C, 95 % RH
Vibration, sinusoidal	IEC/EN 60255-21-1	Class 2
Shock, half-sine	IEC/EN 60255-21-2	Class 2

Isolation data

Rated impulse withstand voltage U_{imp} (IEC/EN 60947-1, IEC/EN 60664-1)	supply circuit / measuring circuit	6 kV
	supply circuit / output circuits	6 kV
	measuring circuit / output circuits	6 kV
	output circuit 1 / output circuit 2	4 kV
Pollution degree (IEC/EN 60664-1)		3
Overvoltage category (IEC/EN 60664-1)		III
Rated insulation voltage U_i (IEC/EN 60947-1, IEC/EN 60664-1)	supply circuit / measuring circuit	600 V
	supply circuit / output circuits	300 V
	measuring circuit / output circuits	600 V
	output circuit 1 / output circuit 2	300 V
Basic insulation for rated control supply voltage (IEC/EN 60664-1)	supply circuit / measuring circuit	400 V AC / 600 V DC
	supply circuit / output circuits	250 V AC / 300 V DC
	measuring circuit / output circuits	400 V AC / 600 V DC
	output circuit 1 / output circuit 2	250 V AC / 300 V DC
Protective separation (IEC/EN 61140, EN 50178)	supply circuit / output circuits	250 V AC / 250 V DC
	supply circuit / measuring circuit	250 V AC / 250 V DC
	measuring circuit / output circuits	250 V AC / 250 V DC
Test voltage (IEC/EN 60255-5, IEC/EN 61010-1)	supply circuit / output circuits	2.32 kV, 50 Hz, 2 s
	supply circuit / measuring circuit	2.32 kV, 50 Hz, 2 s
	measuring circuit / output circuits	2.53 kV, 50 Hz, 1 s

Standards

Product standard	IEC/EN 61557-8, IEC/EN 60255-6
Other standards	EN 50178
Low Voltage Directive	2006/95/EC
EMC Directive	2004/108/EC
RoHS Directive	2002/95/EC

Electromagnetic compatibility

Interference immunity to		IEC/EN 61000-6-1, IEC/EN 61000-6-2, IEC/EN 61326-2-4
electrostatic discharge	IEC/EN 61000-4-2	Level 3, 6 kV / 8 kV
radiated, radio-frequency, electromagnetic field	IEC/EN 61000-4-3	Level 3, 10 V/m (1 GHz) / 3 V/m (2 GHz) / 1 V/m (2.7 GHz)
electrical fast transient/burst	IEC/EN 61000-4-4	Level 3, 2 kV / 5 kHz
surge	IEC/EN 61000-4-5	Level 3, installation class 3, supply circuit and measuring circuit 1 kV L-L, 2 kV L-earth
conducted disturbances, induced by radio-frequency fields	IEC/EN 61000-4-6	Level 3, 10 V
voltage dips, short interruptions and voltage variations	IEC/EN 61000-4-11	Class 3
harmonics and interharmonics	IEC/EN 61000-4-13	Class 3
Interference emission		IEC/EN 61000-6-3, IEC/EN 61000-6-4
high-frequency radiated	IEC/CISPR 22, EN 55022	Class B
high-frequency conducted	IEC/CISPR 22, EN 55022	Class B

Technical diagrams

Load limits curves

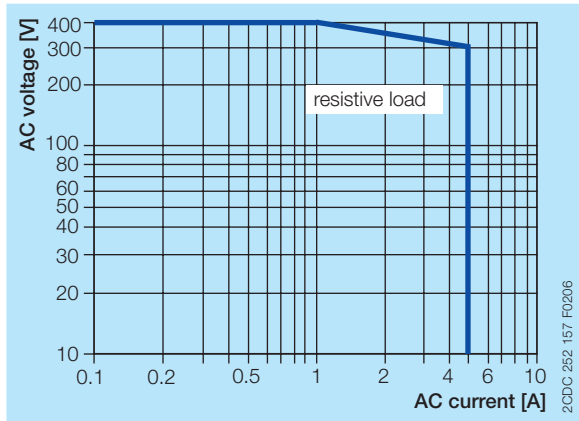

AC load (resistive)

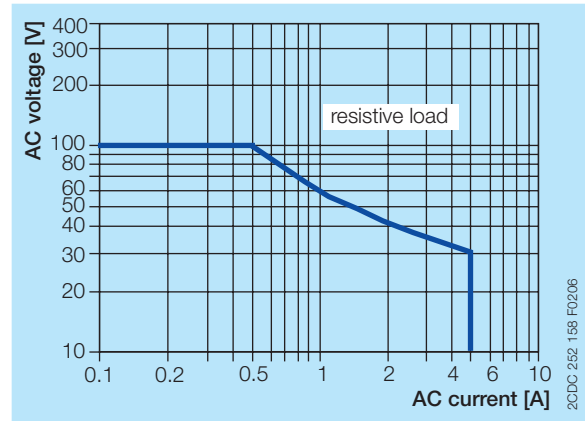

DC load (resistive)

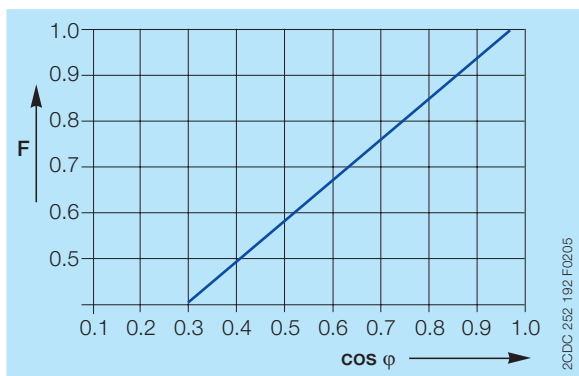

Derating factor F at inductive AC load

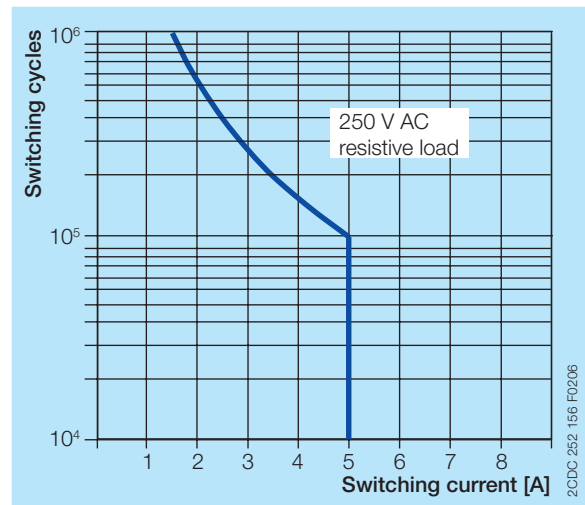

Contact lifetime

Dimensions

in **mm** and *inches*

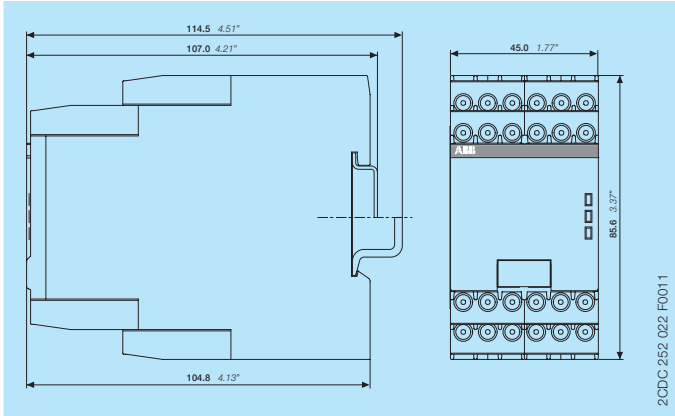

Accessories

in **mm** and *inches*

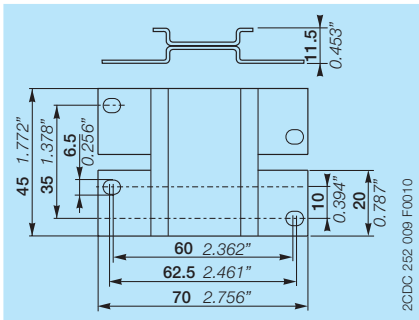

ADP.02 - Adapter for screw mounting

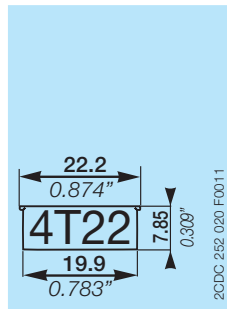

MAR.12 - Marker label for devices with DIP switches

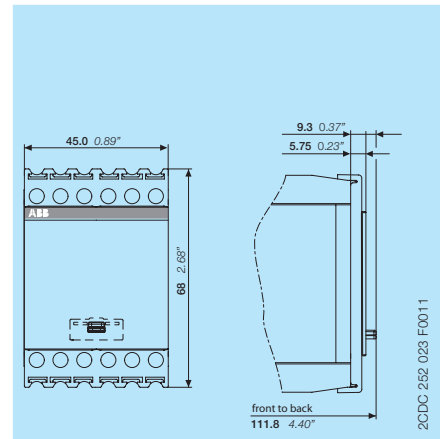

COV.12 - Sealable transparent cover with DIP switches

Further documentation

Document title	Document type	Document number
Electronic products and relays	Catalog	2CDC 110 004 C020x
CM-IWN.1, CM-IWN.4, CM-IWN.5, CM-IWN.6	Instruction sheet	1SVC 750 020 M0000

You can find the documentation on the internet at www.abb.com/lowvoltage -> Control Products -> Electronic Relays and Controls -> Insulation Monitors.

Contact us

ABB STOTZ-KONTAKT GmbH

P. O. Box 10 16 80
69006 Heidelberg, Germany
Phone: +49 (0) 6221 7 01-0
Fax: +49 (0) 6221 7 01-13 25
E-mail: info.desto@de.abb.com

You can find the address of your
local sales organisation on the
ABB home page
<http://www.abb.com/contacts>
-> Low Voltage Products and Systems

Note:

We reserve the right to make technical changes or modify the contents of this document without prior notice. With regard to purchase orders, the agreed particulars shall prevail. ABB AG does not accept any responsibility whatsoever for potential errors or possible lack of information in this document.

We reserve all rights in this document and in the subject matter and illustrations contained therein. Any reproduction, disclosure to third parties or utilization of its contents – in whole or in parts – is forbidden without prior written consent of ABB AG.

Copyright© 2012 ABB
All rights reserved